

Gentle Forest



Featuring fabrics from the **Gentle Forest** collection by **Tea and Sympathy** for **STUDIO·e·fabrics**

Fabric Requirements

Red Color Way

(A) 3041-99	1 panel
(B) 3043-39	2 yards
(C) Paprika-32	1 ½ yards**
(D) 3047-99	¼ yard
(E) 3042-09	¼ yard
(F) 3045-99	⅓ yard
(G) 3047-38	⅓ yard
(H) 3044-99	⅞ yard
(I) 3046-33	⅞ yard*

Backing

3042-09 3 ¼ yards

Pink Color Way

(A) 3041-22	1 panel
(B) 3043-92	2 yards
(C) Magenta-42	1 ½ yards**
(D) 3047-55	¼ yard
(E) 3042-09	¼ yard
(F) 3045-09	⅓ yard
(G) Fuchsia-40	⅓ yard**
(H) 3044-22	⅞ yard
(I) 3046-22	⅞ yard*

Backing

3042-09 3 ¼ yards

Additional Supplies Needed

Batting 56" x 71"

Piecing and sewing thread

Quilting and sewing supplies

Quilt designed by Megan Downer

Finished Quilt Size 48" x 63"

* Includes Binding

** Peppered Cotton Collection

Cutting

Cutting Instructions

Please note: All strips are cut across the width of fabric (WOF) from selvage to selvage edge.

WOF= Width of Fabric • LOF = Length of Fabric

Red Color Way listed first, followed by Pink Color Way

Fabric A (3041-99 Picture Frames – Gray)/(3041-22 Picture Frames – Pink)

- Fussy cut (12) 6 ½" x 7 ½" small panels, each centered on a scene.

Fabric B (3043-39 Floral Vine – Orange/Gray)/(3043-92 Floral Vine – Pink/Gray)

- (4) 5 ½" x WOF strips, sub-cut (48) 2 ¾" x 5 ½" strips.
- (4) 5 ½" x WOF strips, sub-cut (48) 3" x 5 ½" strips.
- (3) 3 ¾" x WOF strips, sub-cut (48) 2" x 3 ¾" strips.
- (3) 4" x WOF strips, sub-cut (48) 2 ½" x 4" strips.

Fabric C (Paprika-32 Peppered Cottons – Paprika)/(Magenta-42 Peppered Cottons – Magenta)

- (4) 5 ½" x WOF strips, sub-cut (48) 2 ¾" x 5 ½" strips.
- (4) 5 ½" x WOF strips, sub-cut (48) 3" x 5 ½" strips.
- (3) 1" x WOF strips. Sew strips together, end to end with diagonal seams, and cut (2) 1" x 48 ½" strips.
- (2) 1" x 34 ½" WOF strips.

Fabric D (3047-99 Snails – Gray)/(3047-55 Snails – Orchid)

- (2) 3 ⅜" x WOF strips, sub-cut (24) 3 ⅜" squares.

Fabric E (3042-09 Gentle Forest Scenic – White)/(3042-09 Gentle Forest Scenic – White)

- (2) 3 ⅜" x WOF strips, sub-cut (24) 3 ⅜" squares.

Fabric F (3045-99 Hedgehog – Gray)/(3045-09 Hedgehog – White)

- (3) 1 ½" x WOF strips. Sew strips together, end to end with diagonal seams, and cut (2) 1 ½" x 49 ½" strips.
- (2) 1 ½" x 36 ½" WOF strips.

Fabric G (3047-38 Snail – Orange)/(Fuchsia-40 Peppered Cottons – Fuchsia)

- (3) 1 ½" x WOF strips. Sew strips together, end to end with diagonal seams, and cut (2) 1 ½" x 51 ½" strips.
- (2) 1 ½" x 38 ½" WOF strips.

Fabric H (3044-99 Circle Toss – Gray)/(3044-22 Circle Toss – Pink)

- (3) 4 ½" x WOF strips. Sew strips together, end to end with diagonal seams, and cut (2) 4 ½" x 46 ½" strips.
- (3) 4 ½" x WOF strips. Sew strips together, end to end with diagonal seams, and cut (2) 4 ½" x 53 ½" strips.

Fabric I (3046-33 Wood Grain – Brown)/(3046-22 Wood Grain – Pink)

- (4) 1 ½" x WOF strips. Sew strips together, end to end with diagonal seams, and cut (2) 1 ½" x 61 ½" strips.
- (3) 1 ½" x WOF strips. Sew strips together, end to end with diagonal seams, and cut (2) 1 ½" x 48 ½" strips.
- (6) 2 ½" x WOF strips for the binding.

Backing (3042-09 Gentle Forest Scenic – White)/ (3042-09 Gentle Forest Scenic – White)

- (2) 56" x WOF strips. Sew the strips together and trim to 56" x 71" for the back.

Sewing

Sew using a $\frac{1}{4}$ " seam allowance with right sides together (RST) unless otherwise indicated. Always press towards the darker fabric while assembling, unless otherwise noted by the arrows.

Block Assembly

1. Make (24) copies of each paper piecing templates.

2. Using your favorite paper piecing method and the fabrics listed on the Top/Bottom Right Unit templates, make (24) Right BC short unit (Fig. 1).

3. Using your favorite paper piecing method and the fabrics listed on the Top/Bottom Right Unit templates, make (24) Left BC short Unit (Fig. 2).

4. Sew together one Right BC short unit and one Left BC short unit to make one Top/Bottom block border (Fig. 3). Repeat to make (24) Top/Bottom block borders.

make 24



Fig. 1

make 24



Fig. 2

make 24

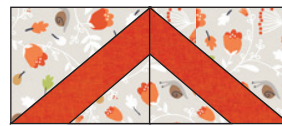

Fig. 3

5. Using your favorite paper piecing method and the fabrics listed on the Side Right Unit templates, make (24) Right BC long units (Fig. 4).

6. Using your favorite paper piecing method and the fabrics listed on the Side Left Unit templates, make (24) Left BC long units (Fig. 5).

7. Sew together one Right BC long unit and one Left BC long unit to make one Side block border (Fig. 6). Repeat to make (24) Side block borders.

make 24



Fig. 4

make 24



Fig. 5

make 24



Fig. 6

8. Place (1) $3\frac{3}{8}$ " Fabric D square on top of (1) $3\frac{3}{8}$ " Fabric E square, right sides together. Draw a line across the diagonal of the top square (Fig. 7). Sew $\frac{1}{4}$ " away from each side of the drawn diagonal line (Fig. 7). Cut the two squares apart on the drawn diagonal line (Fig. 8) to make (2) DE units (Fig. 9). Trim DE units to measure 3" square. Repeat to make (48) DE units total.

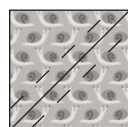

Fig. 7

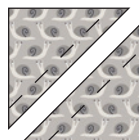

Fig. 8

make 48

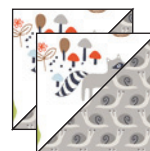

Fig. 9

9. Sew together two top/bottom block borders, two side block borders, four DE units and one 6 1/2" x 7 1/2" Fabric A panel to make one Block (Fig. 10). Repeat to make twelve blocks total.

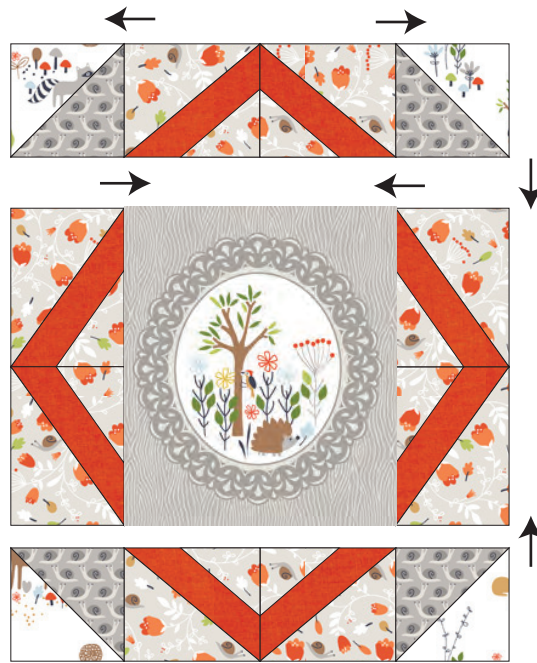

Fig. 10

Quilt Top

10. Sew (3) blocks together to make one row. Repeat to make four rows. Sew the rows together to make the quilt top (Fig. 11)



Fig. 11

11. Sew (1) 1" x 48 1/2" Fabric C strip to each side of the quilt top. Sew (1) 1" x 34 1/2" Fabric C strip to the top and to the bottom of the quilt top (Fig. 12).

12. Sew (1) 1 1/2" x 49 1/2" Fabric F strip to each side of the quilt top. Sew (1) 1 1/2" x 36 1/2" Fabric F strip to the top and to the bottom of the quilt top (Fig. 13).



Fig. 12



Fig. 13

13. Sew (1) 1 ½" x 51 ½" Fabric G strip to each side of the quilt top. Sew (1) 1" x 38 ½" Fabric G strip to the top and to the bottom of the quilt top (Fig. 14).

14. Sew (1) 4 ½" x 53 ½" Fabric H strip to each side of the quilt top. Sew (1) 4 ½" x 46 ½" Fabric H strip to the top and to the bottom of the quilt top (Fig. 15).



Fig. 14



Fig. 15

15. Sew (1) 1 ½" x 61 ½" Fabric I strip to each side of the quilt top. Sew (1) 1 ½" x 48 ½" Fabric H strip to the top and to the bottom of the quilt top (Fig. 16).



Fig. 16

Layering, Quilting and Finishing

16. Press the quilt top and 56" x 71" backing well. Layer backing (wrong side up), batting, pressed quilt top (right side up) and baste. Quilt as desired and trim excess batting and backing when quilting is complete.

Binding

17. Cut the ends of the (6) Fabric I binding strips at a 45-degree angle and sew end to end to make (1) continuous piece of binding. Fold in half lengthwise and press wrong sides together.

18. Sew the binding to the front of the quilt, raw edges together. Turn the folded edge to the back, and hand stitch in place.

Paper Piecing Templates

Make 24 copies of these
templates for paper piecing

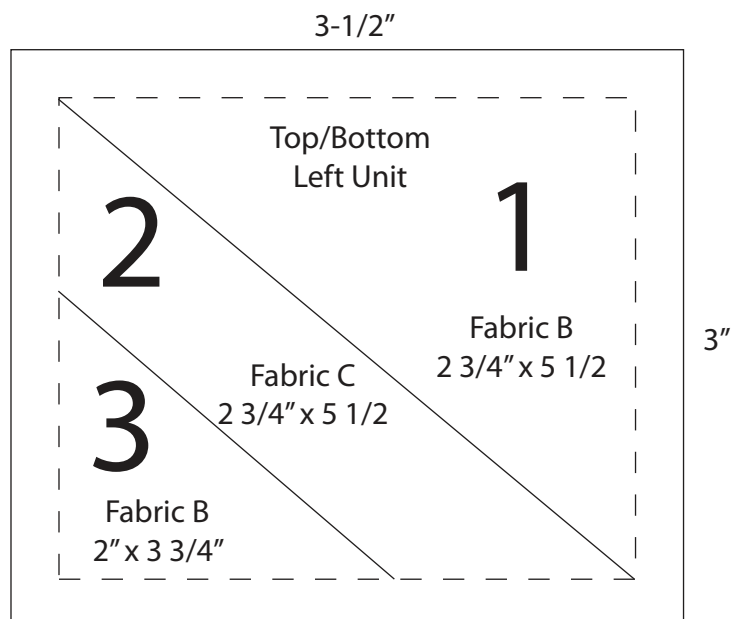
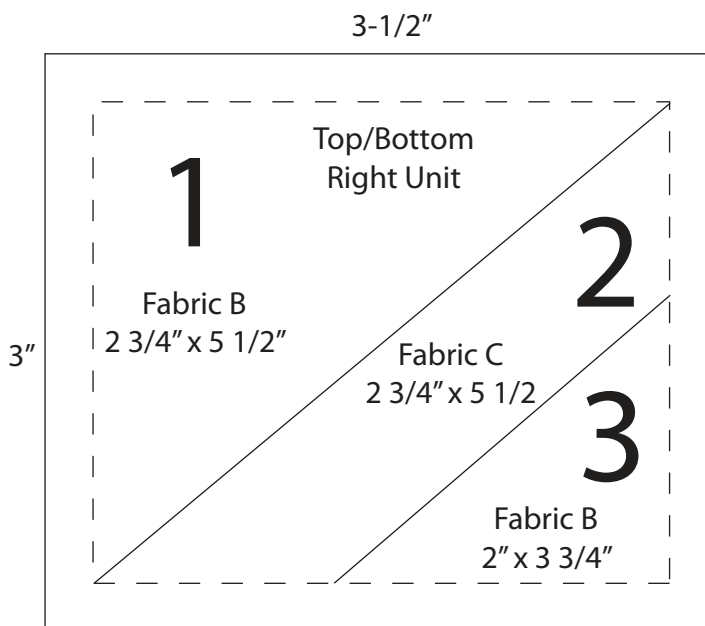

Paper Piecing Templates

Make 24 copies of these
templates for paper piecing

